

# Silverline

SLK024  
SHADOW FORD DNS  
BRAZILIAN G.P. 1976  
SOUTH AFRICAN G.P. 1976  
T. Pryce - J. Pierre Jarier

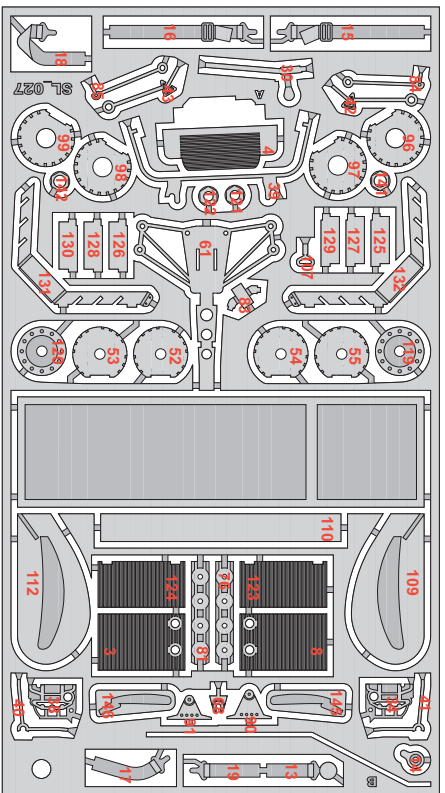

17 - J.P. JARIER

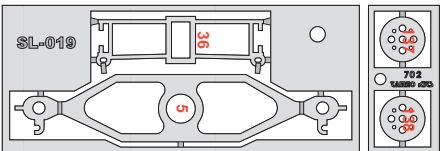

BRAZILIAN GP 1976

SUTTON IMAGES

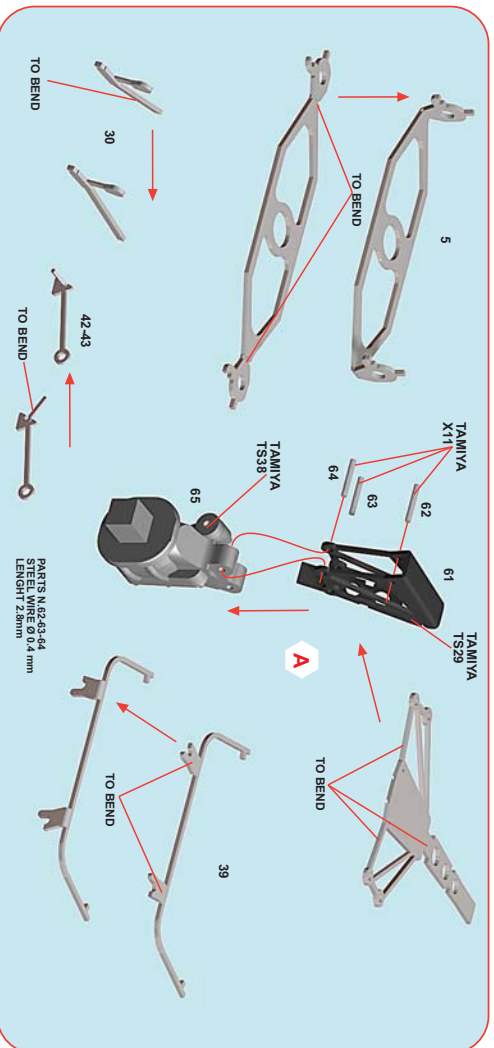

01

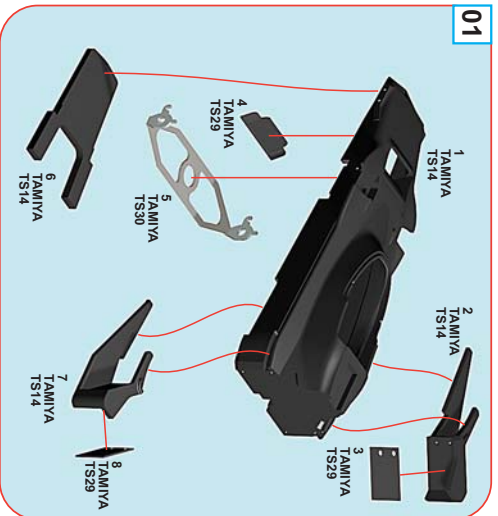

02

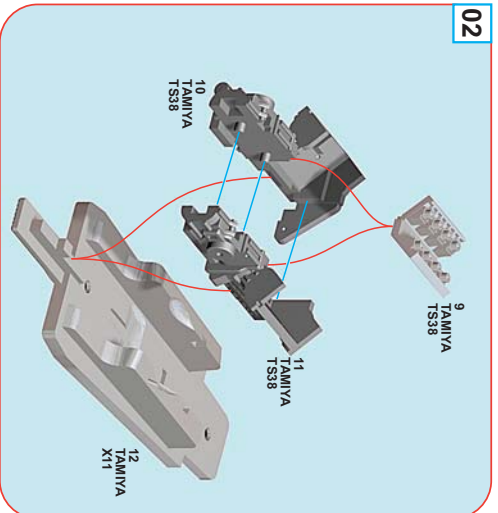

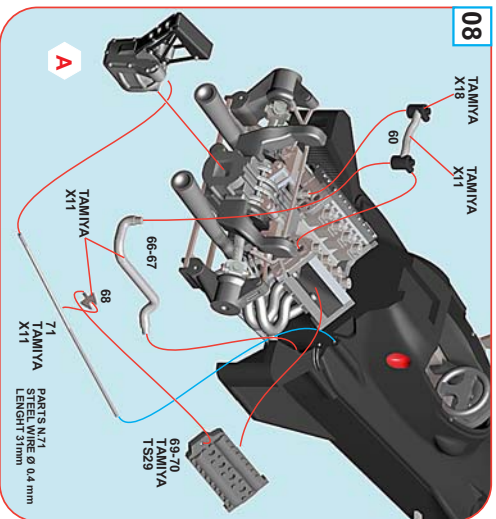
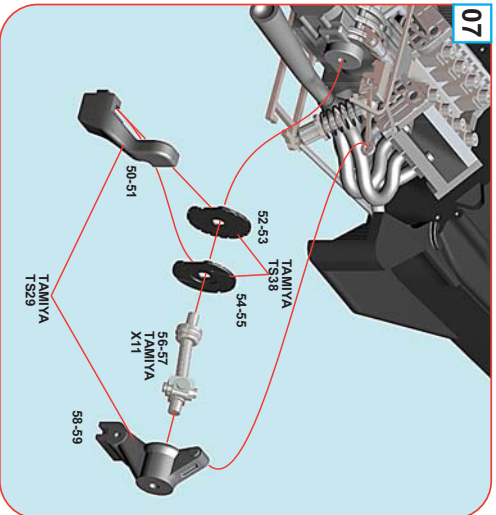
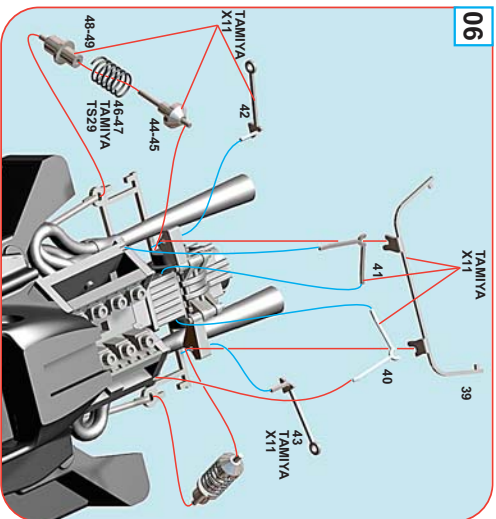
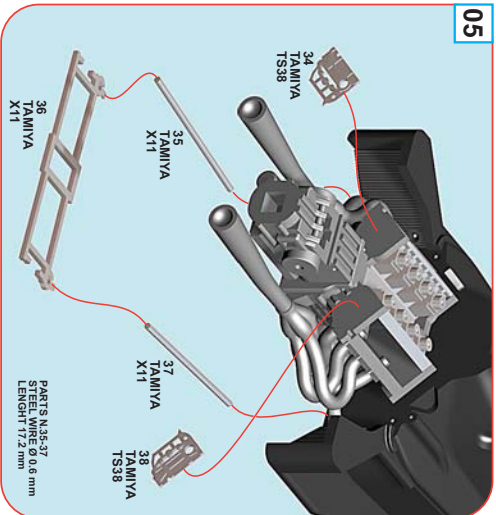
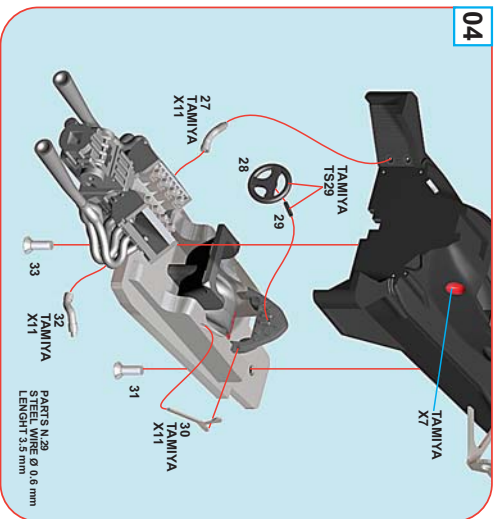
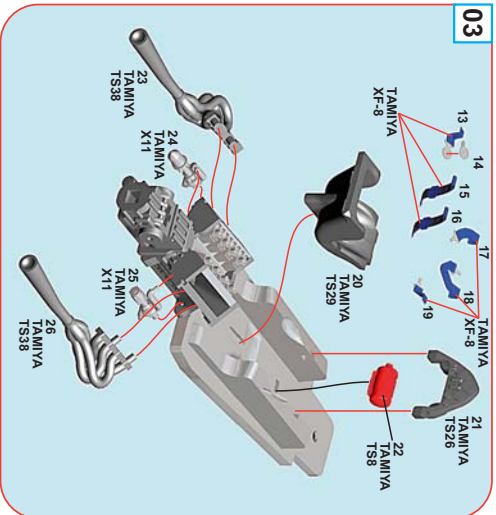

09

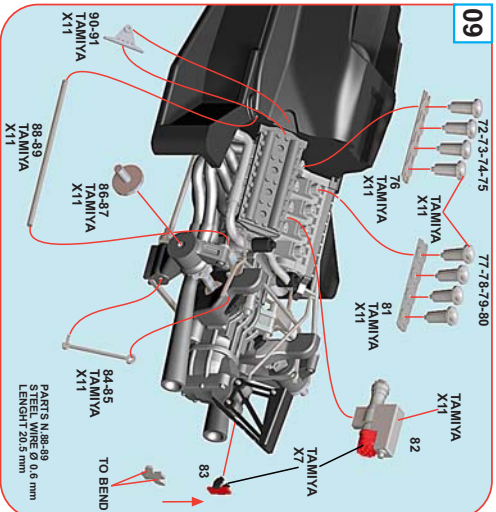

10

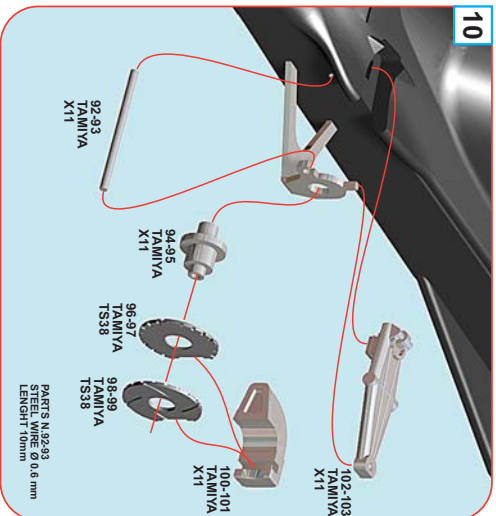

11

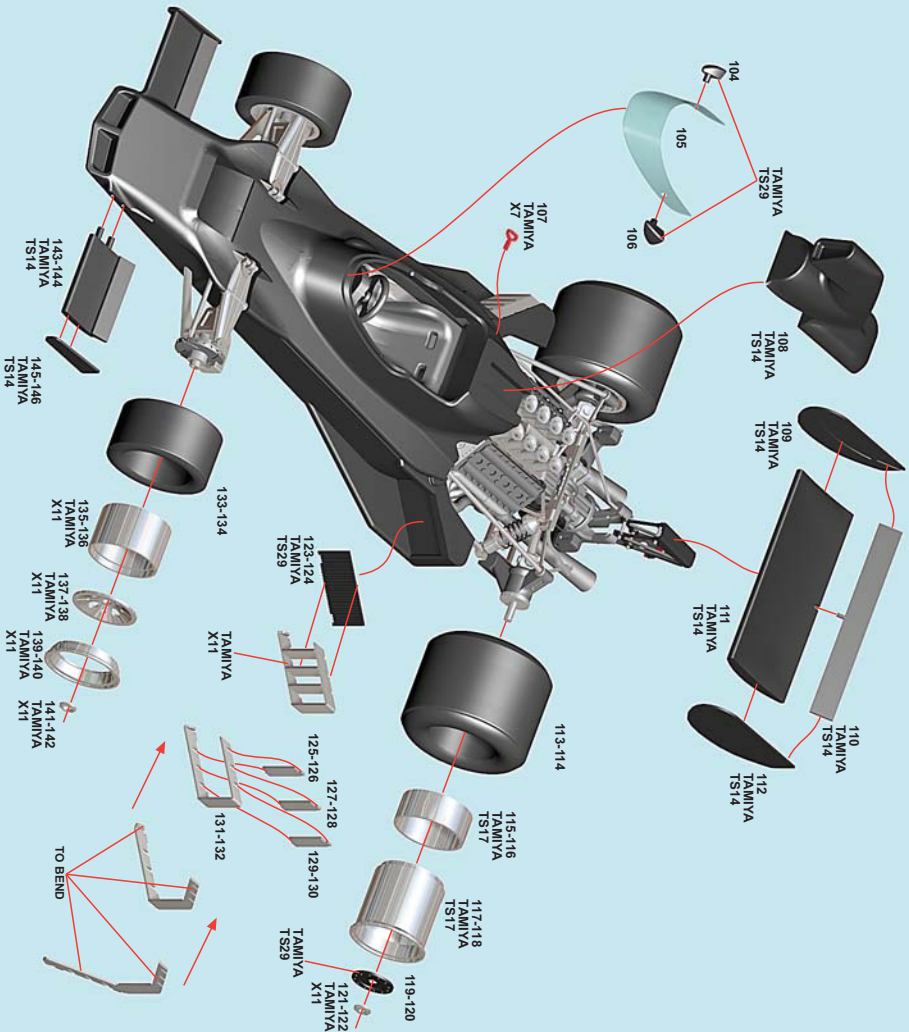

# N°16 Tom Pryce 7th

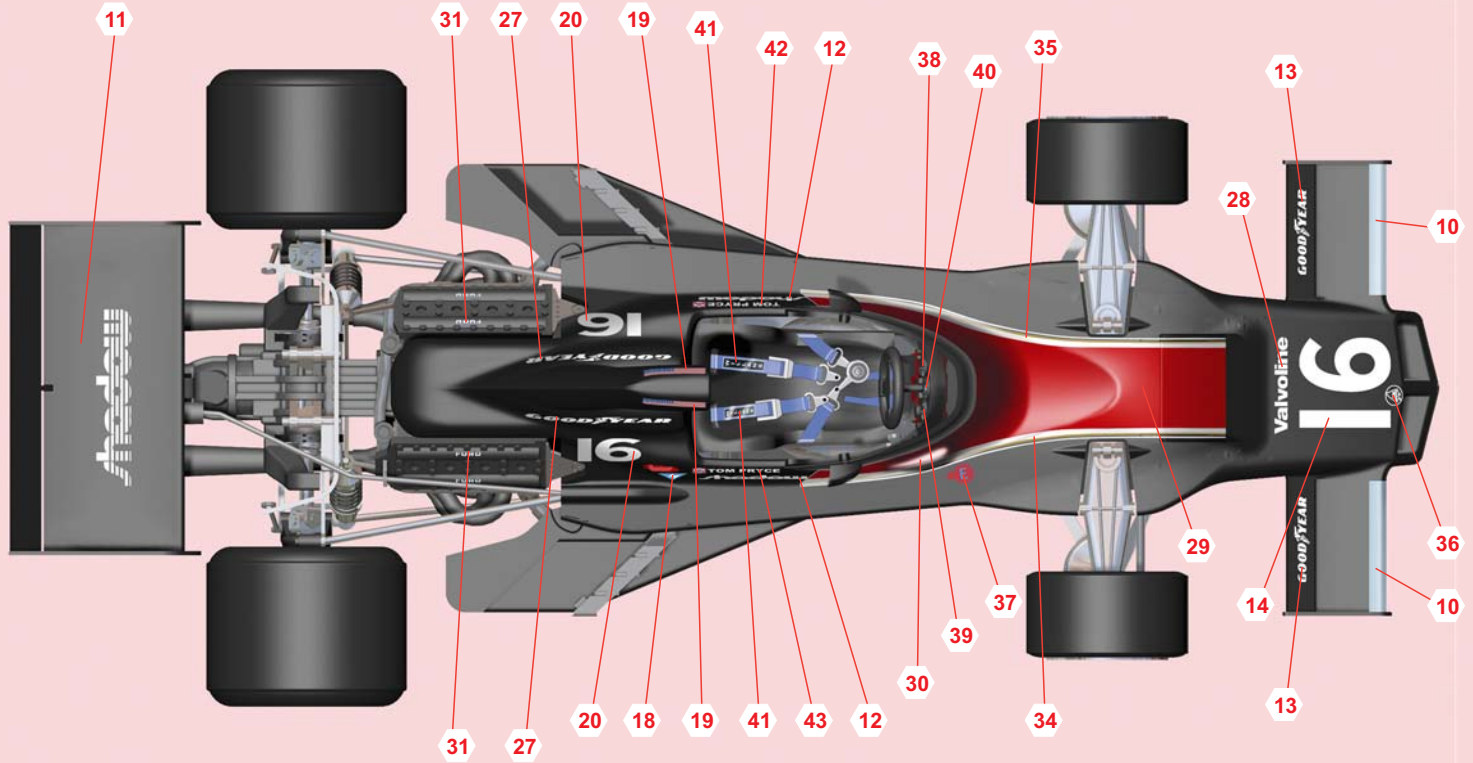

# SLK024 SHADOW FORD DN5 SOUTH AFRICAN G.P. 1976

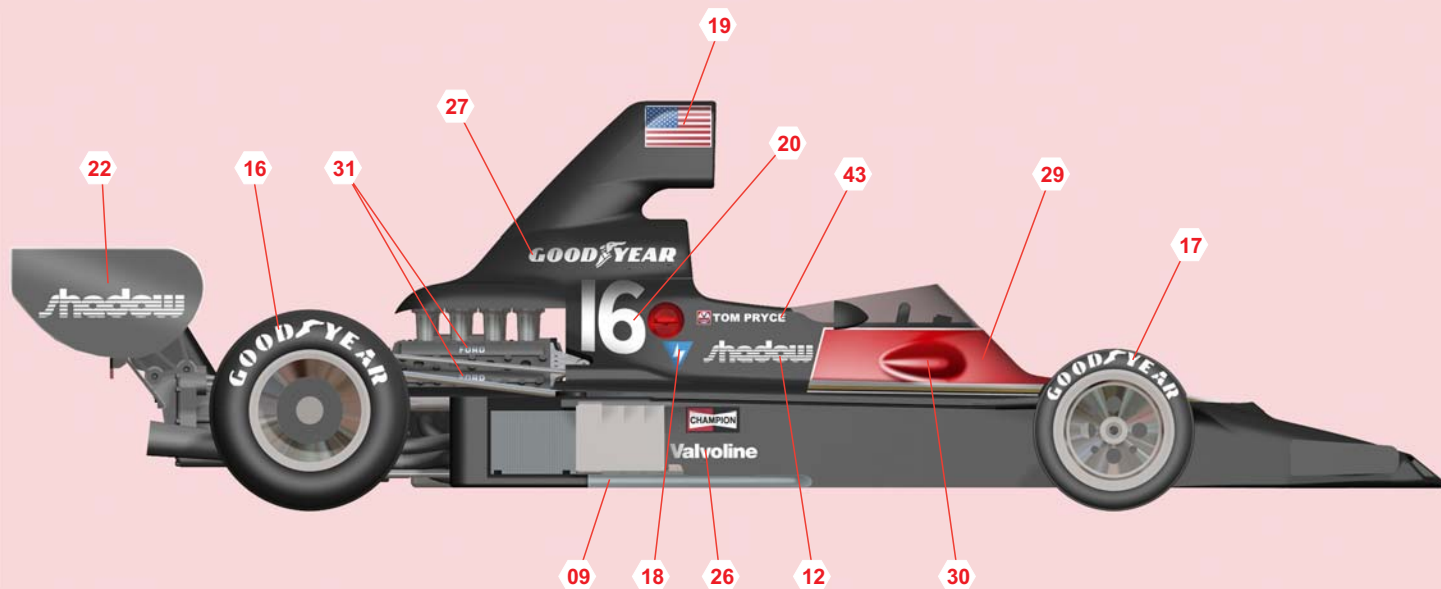

N°17 J. Pierre Jarier Ret.

# SLK024 SHADOW FORD DN5 BRAZILIAN G.P. 1976

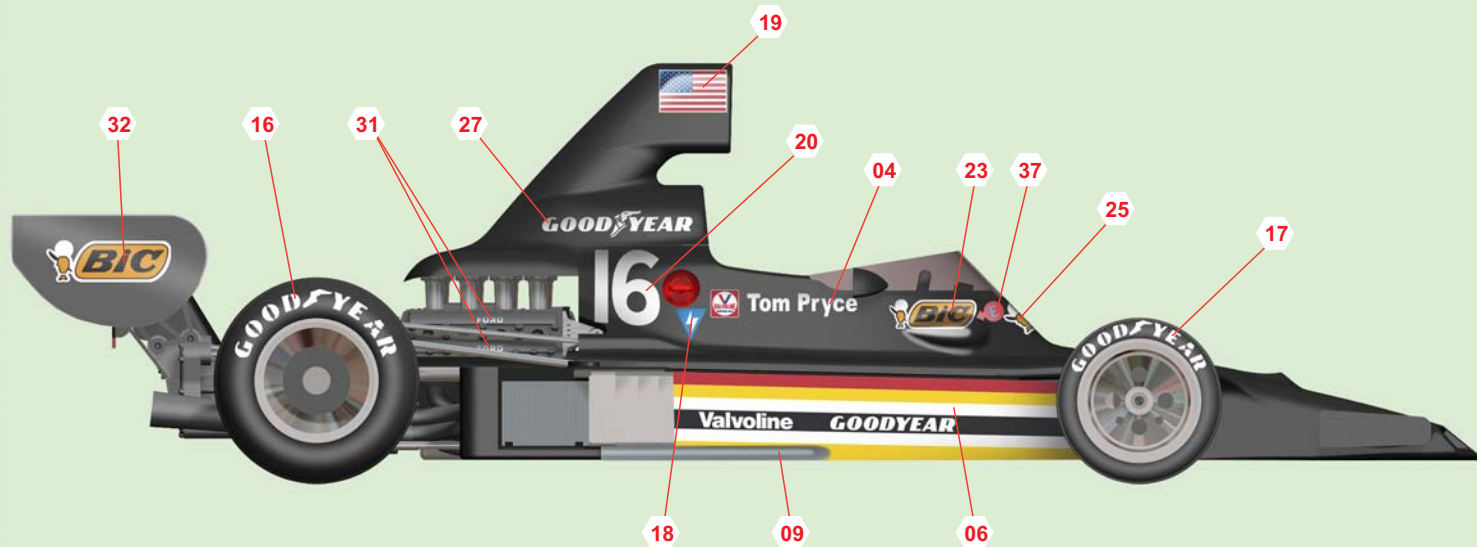

N°17 J. Pierre Jarier Ret.

# N°16 Tom Pryce 3rd

